

OPTIONS

Methods of installation

- embedded in concrete

DESCRIPTION

Aura double-sided bench represents a simple and robust design for modern seating. Universities, Shopping malls, schools, parks, modern squares all must be possible locations for this bench. It is made of stainless steel, which makes products both strong and durable. Stainless steel is low maintenance, resistant to vandalism, strong and durable material. Presented Aura 02.223 city bench complement exterior and interior decorations perfectly.



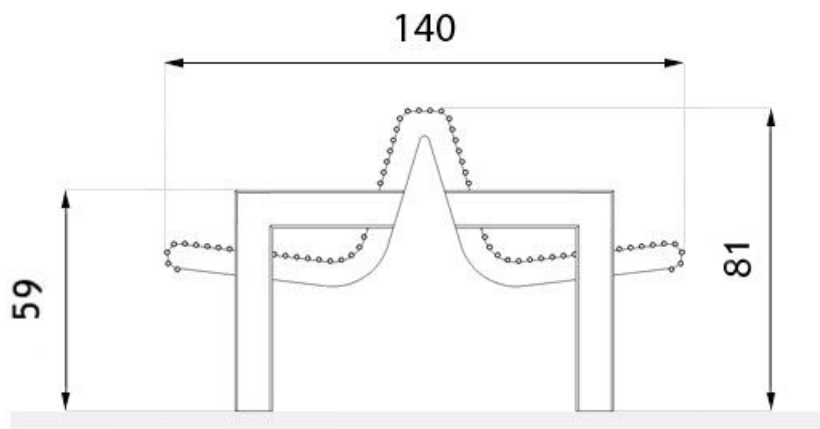

wymiary podane w [cm]

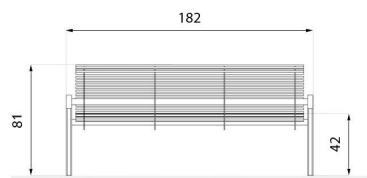

wymiary podane w [cm]

GENERAL TECHNICAL DATA

Weight

- 150 kg

Dimensions

- width: 140 cm
- length: 182 cm
- height: 82 cm

ZANO



M. Welmiński

Product: Aura Bench
Catalog number: 02.223
Designer:
Mateusz Welmiński

In accordance with the Polish Law on Copyright and Related Rights of 04.02.1994 (Official Journal of Laws No. 24, item 83, corrected: Journal of Laws No. 43, item 170) and in accordance with the EU copyright legislation including all EU directives and regulations on copyright, Zano Mirosław Zarotynski Company, reserves the copyright of drawings, descriptions, 3D models, renderings, graphics, content contained in offers, attachments to offers and all other documents. Its content is the intellectual property of ZANO Mirosław Zarotynski company. The use of author's ideas, solutions, copying, distribution of photos, graphics or fragments of graphics, descriptive texts, for profit, without the permission of the author - ZANO Mirosław Zarotynski company - is prohibited and constitutes a copyright infringement and is punishable.

NOTE: The drawings do not reflect the actual dimensions of the foundation. They are only exemplary assembly schemes taking into account the type of anchoring and the substrate material to which the furniture is to be fixed.

The size of the foundation depends on the local foundation conditions.



INSTALLATION INTO PAVING WITH FOUNDATION

Description of the assembly

1. ZANO product
2. Stone paving / concrete paving / stone slabs / concrete slabs
3. Sand ballast (approx. 2 - 4 cm)
4. Concrete foundation, class C16/20 (top surface concrete 10 cm below paving surface)
5. Ground



MOUNTING TO CONCRETE FOUNDATION

Description of the assembly

1. ZANO product
2. Concrete foundation, class C16/20 (top surface concrete 10 cm below paving surface)
3. Ground

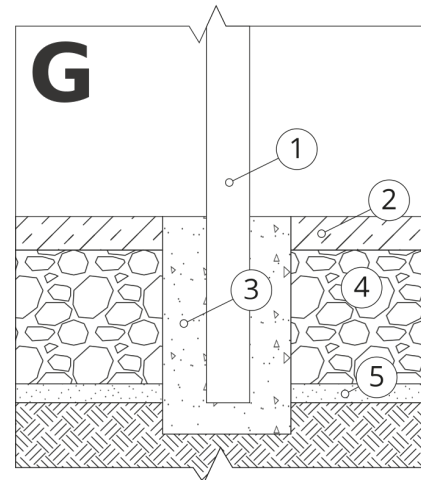

MOUNTING TO CONCRETE FOUNDATION

Description of the assembly

1. ZANO product
2. Fixed hardened surface e.g. concrete or asphalt
3. Concrete foundation, class C16/20 (top surface concrete 10 cm below paving surface)
4. Stone aggregate substructure
5. Sand ballast (approx. 2 - 4 cm)
6. Ground